

# Guia tipo A

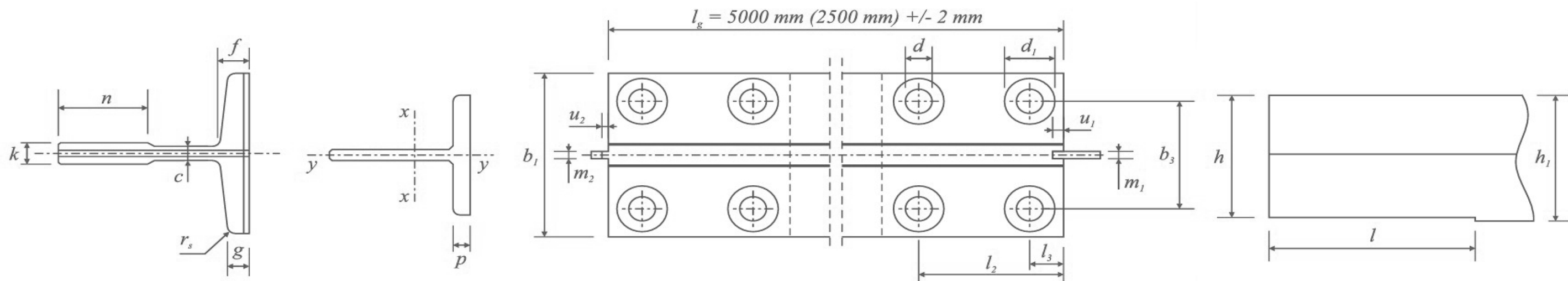

Código Code	Dimensões da Guia de Elevador Tipo A - Unidade mm.													
	$b_1$	$h_1$		$k$	$p$	$r_s$	$m_1$	$u_1$	$m_2$	$u_2$	$d$	$b_3$	$l_2$	$l_3$
Tolerance Tolerância	$\pm 1$	$\pm 0,20$		$\pm 0,15$	$\pm 0,5$		$0 / + 0,06$	$\pm 0,10$	$0 / - 0,06$	$\pm 0,10$		$\pm 0,20$	$\pm 0,20$	$\pm 0,20$
T45/A	45	45		5	5	1	2	2,5	1,95	2	9	25	65	15
T50/A	50	50		5	5	1	2	2,5	1,95	2	9	30	75	25



# Guia tipo B



Código Code	Dimensões da Guia de Elevador Tipo B - Unidade mm.																		
	$b_1$	$h_1$	$h$	$k$	$n$	$c$	$f$	$g$	$r_s$	$m_1$	$u_1$	$m_2$	$u_2$	$d$	$d_1$	$b_3$	$l_2$	$l_3$	$l$
Tolerance Tolerância	$\pm 1,5$	$\pm 0,75$	$\pm 0,10$	$0/+0,10$	$0/+3$		$\pm 0,75$	$\pm 0,75$		$0/+0,06$	$\pm 0,10$	$0/-0,06$	$\pm 0,10$			$\pm 0,20$	$\pm 0,20$	$\pm 0,20$	$0/+3$
T70/B	70	65	64	9	34	6	8	6	1,5	3	3,5	2,97	3	13	26	42	105	25	128
T82/B	82,5	68,25	66,6	9	25,4	7,5	8,25	6	3	3	3,5	2,97	3	13	26	50,8	81	27	111
T89/B	89	62	61	16	34	10	11,1	7,9	3	6,4	7,14	6,37	6,35	13	26	57,2	114,3	38,1	156
T127-1/B	127	89	88	16	42	10	11	8	4	6,4	7,14	6,37	6,35	17	33	79,4	114,3	38,1	156
T127-2/B	127	89	88	16	51	10	15,9	12,7	5	6,4	7,14	6,37	6,35	17	33	79,4	114,3	38,1	156

